

# BP-STYLE DOOR

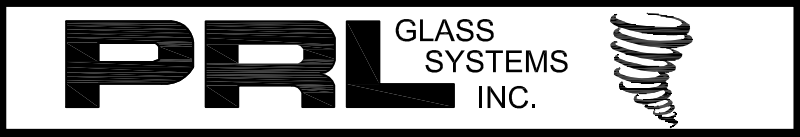

## 9 1/2" PL150 TOP PL150 BOTTOM

\* FINISHES AVAILABLE :  
# 8 POLISHED & # 4 SATIN  
STAINLESS  
US3 POLISHED & US4 SATIN  
BRASS ( NON LACQUER COATED )  
US10B  
ANODIZED PAINTED

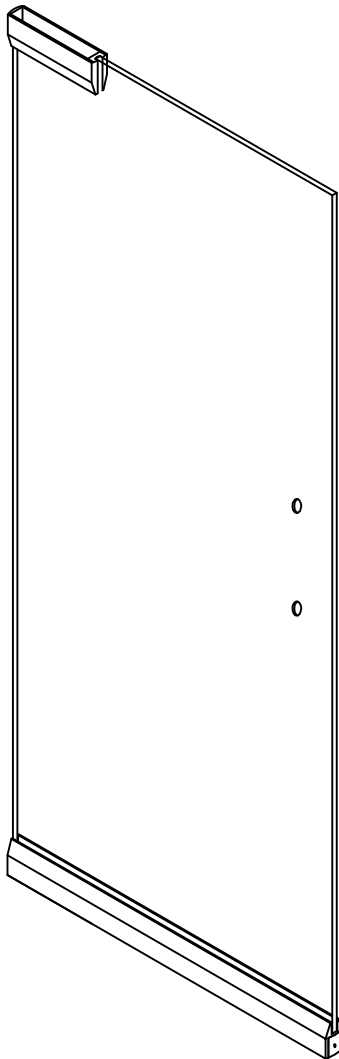

9 1/2" PL-150 TOP PATCH RAIL  
(CLAD) BY P.R.L. GLASS

1/2" CLEAR TEMPERED GLASS  
BY P.R.L. GLASS

PL-150 BTM RAIL  
(CLAD)  
BY P.R.L. GLASS

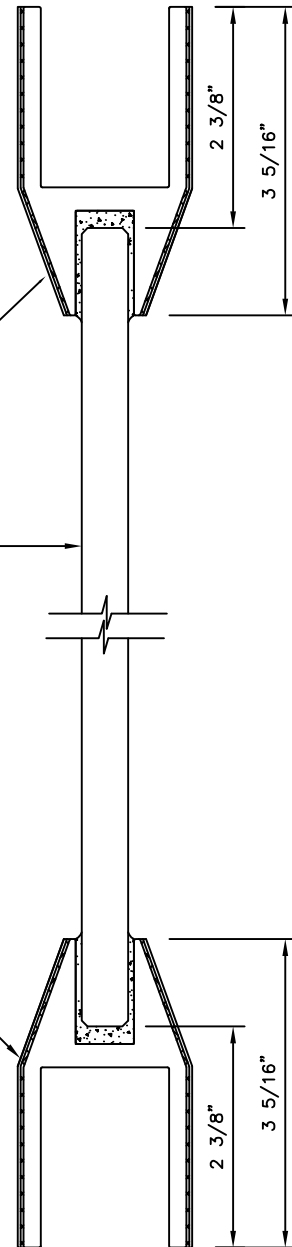

# BP-STYLE DOOR

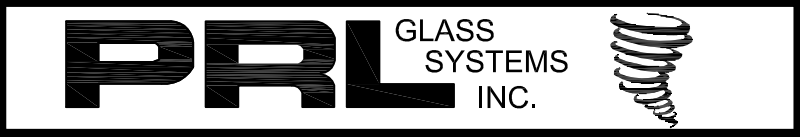

## 9 1/2" PL175 TOP PL175 BOTTOM

\* FINISHES AVAILABLE :  
# 8 POLISHED & # 4 SATIN  
STAINLESS  
US3 POLISHED & US4 SATIN  
BRASS ( NON LACQUER COATED )  
US10B  
ANODIZED PAINTED

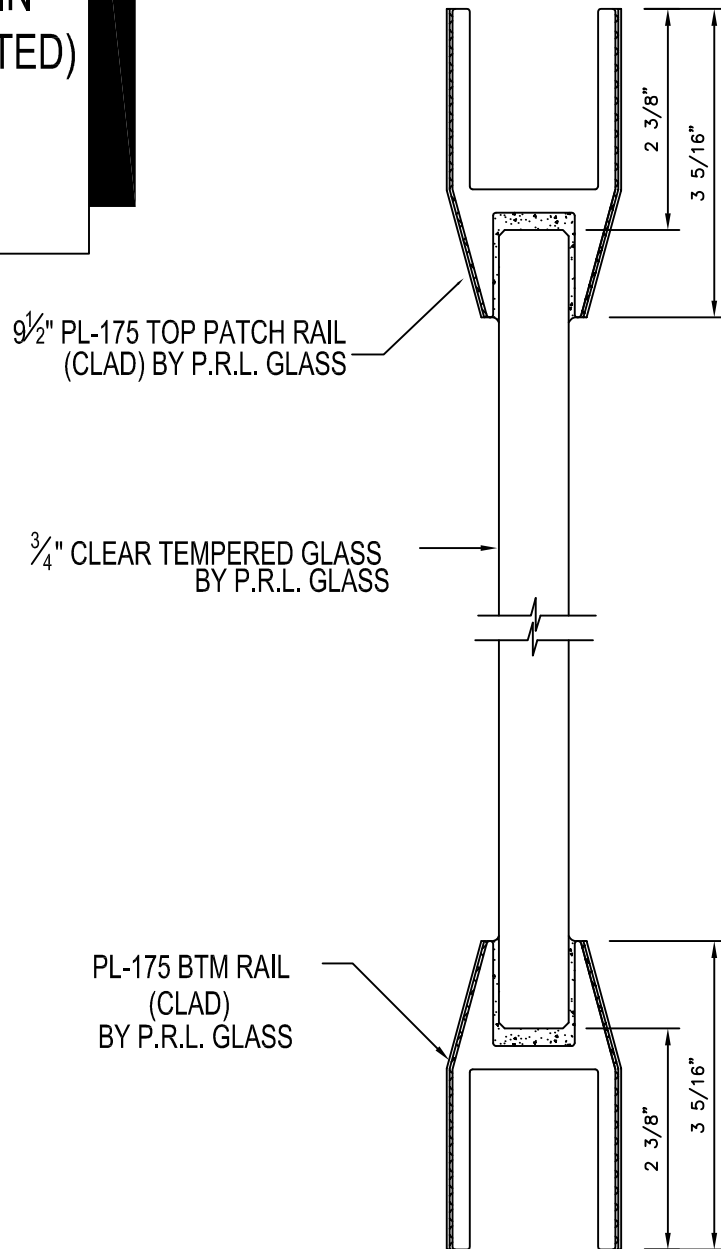
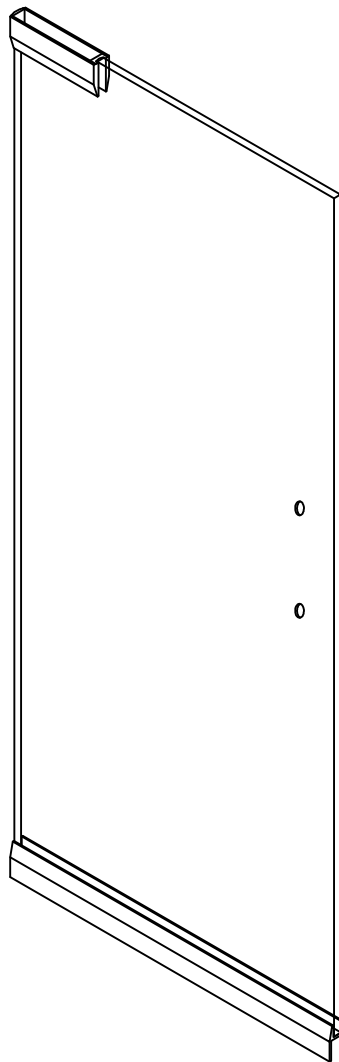

# BP-STYLE DOOR

**PRL** GLASS SYSTEMS INC.



## 9 1/2" PL350 TOP PL350 BOTTOM

★ FINISHES AVAILABLE :  
# 8 POLISHED & # 4 SATIN  
STAINLESS  
US3 POLISHED & US4 SATIN  
BRASS ( NON LACQUER COATED)  
US10B  
ANODIZED PAINTED

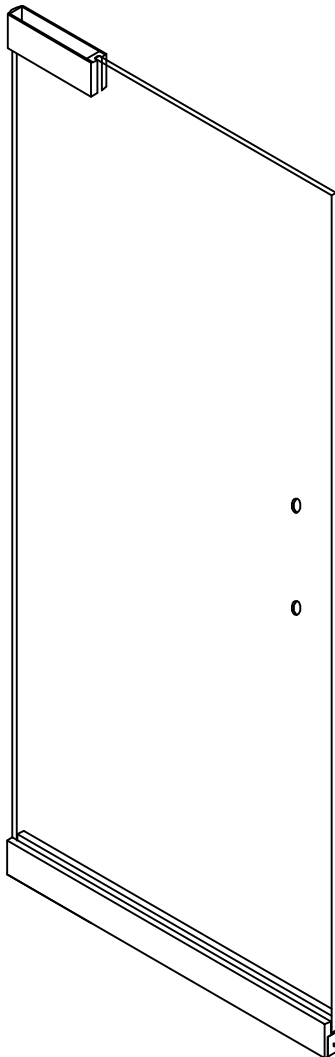

9 1/2" PL-350 TOP PATCH RAIL  
(CLAD) BY P.R.L. GLASS

1/2" CLEAR TEMPERED GLASS  
BY P.R.L. GLASS

PL-350 BTM RAIL  
(CLAD)  
BY P.R.L. GLASS

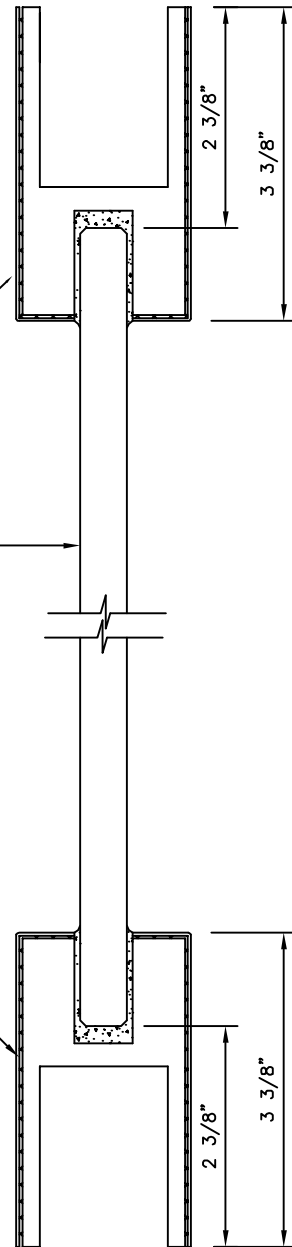

# BP-STYLE DOOR

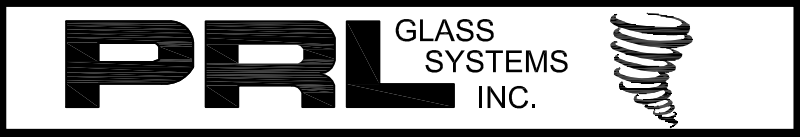

## 9 1/2" PL350 TOP PL1000 BOTTOM

\* FINISHES AVAILABLE :  
# 8 POLISHED & # 4 SATIN  
STAINLESS  
US3 POLISHED & US4 SATIN  
BRASS ( NON LACQUER COATED)  
US10B  
ANODIZED PAINTED

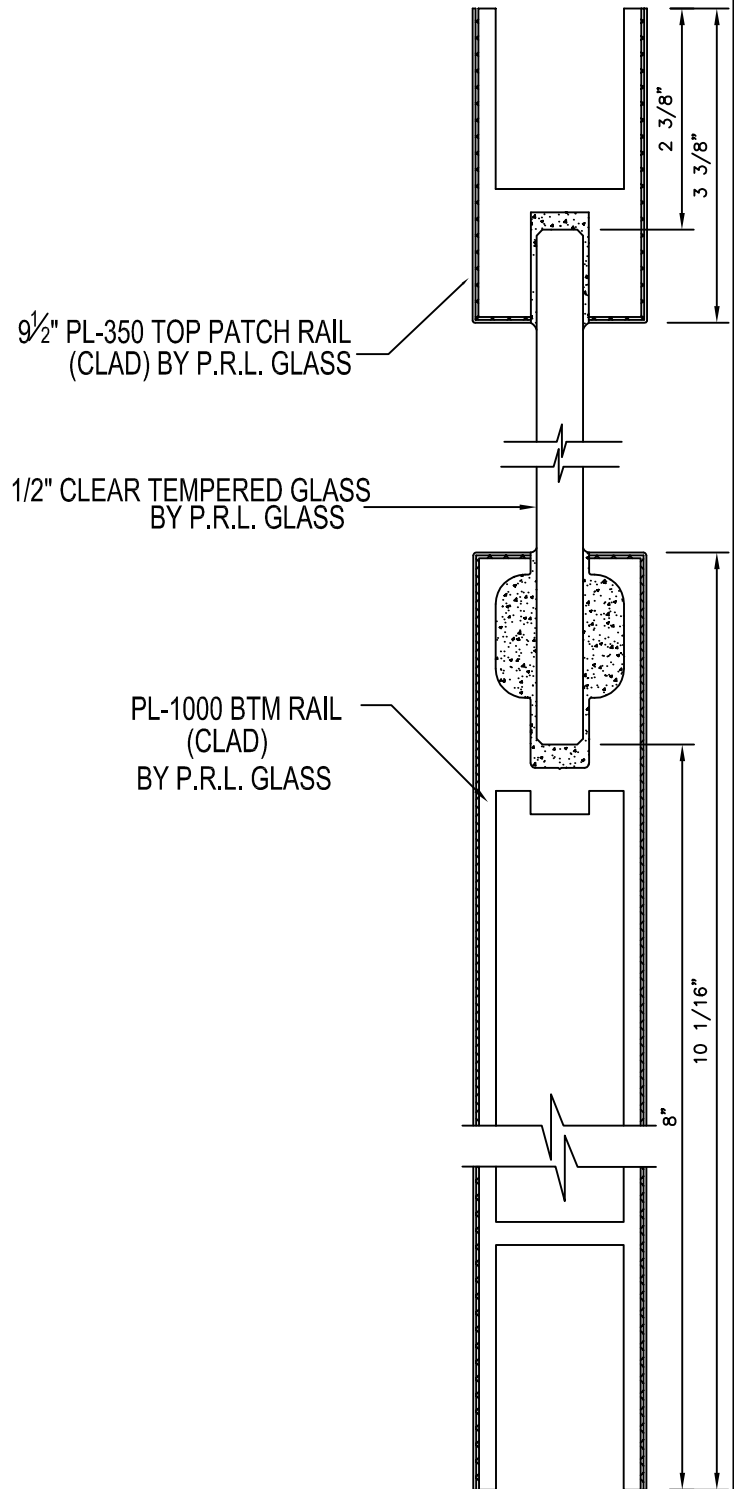
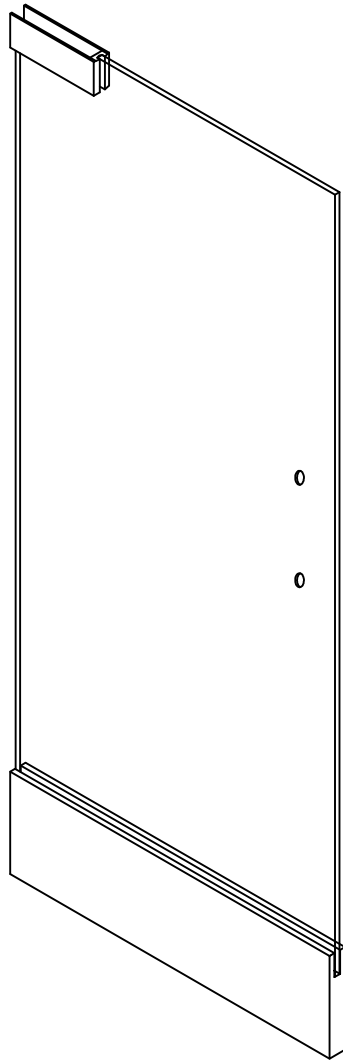

# BP-STYLE DOOR

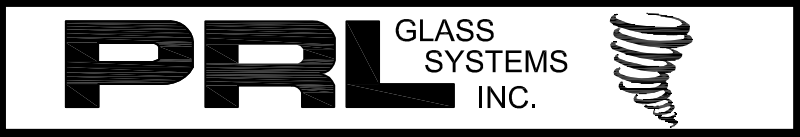

9 1/2" PL350 TOP  
PL387 BOTTOM

\* FINISHES AVAILABLE :  
# 8 POLISHED & # 4 SATIN  
STAINLESS  
US3 POLISHED & US4 SATIN  
BRASS ( NON LACQUER COATED)  
US10B  
ANODIZED PAINTED

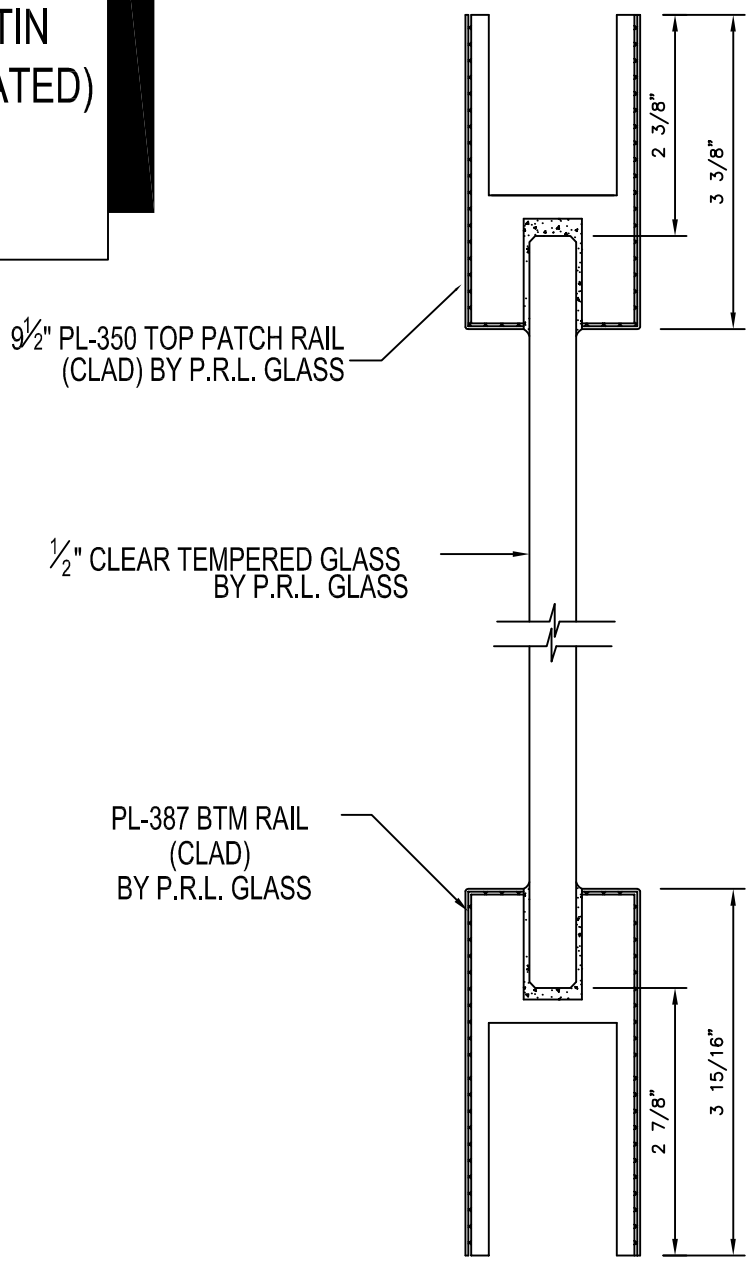
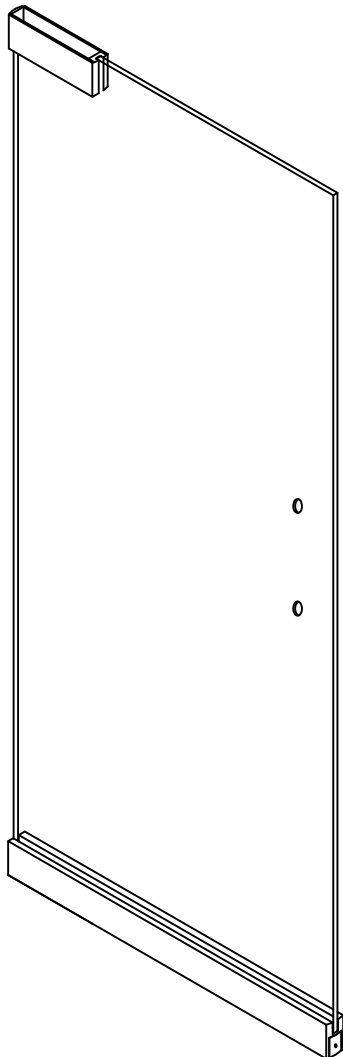

# BP-STYLE DOOR

9 1/2" PL350 TOP  
PL600 BOTTOM

\* FINISHES AVAILABLE :  
# 8 POLISHED & # 4 SATIN  
STAINLESS  
US3 POLISHED & US4 SATIN  
BRASS ( NON LACQUER COATED)  
US10B  
ANODIZED PAINTED

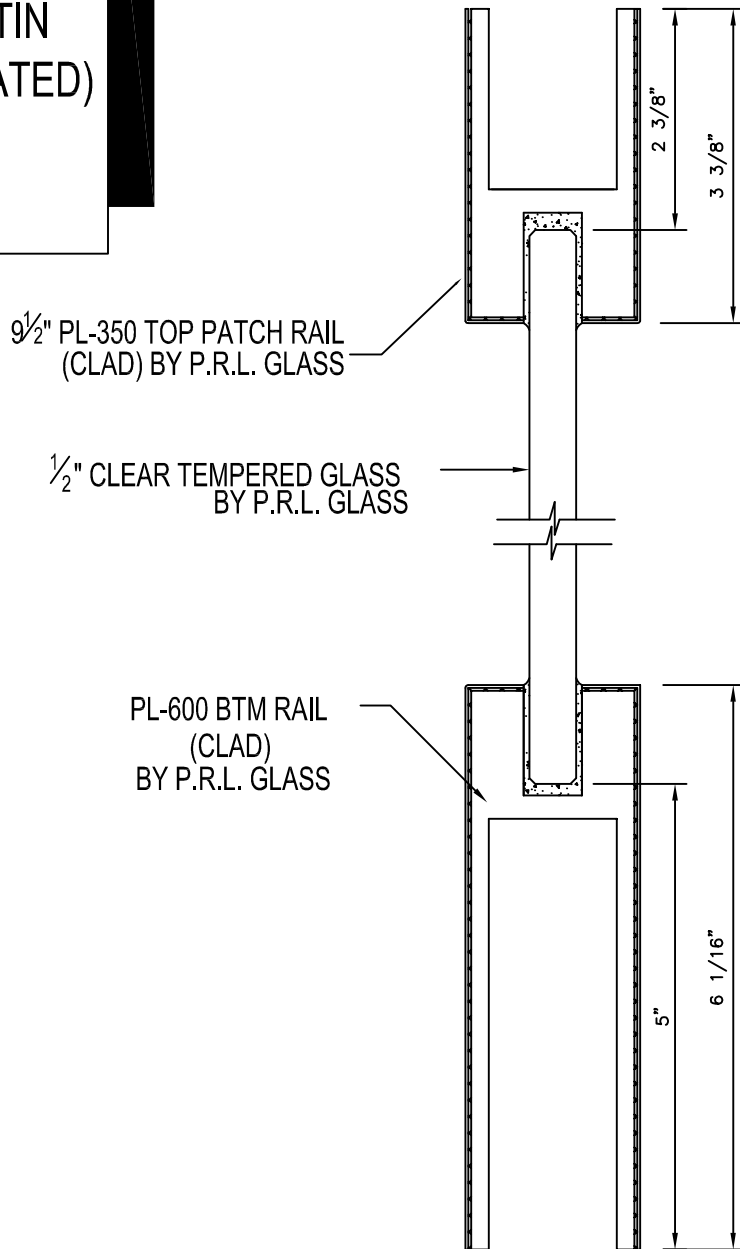
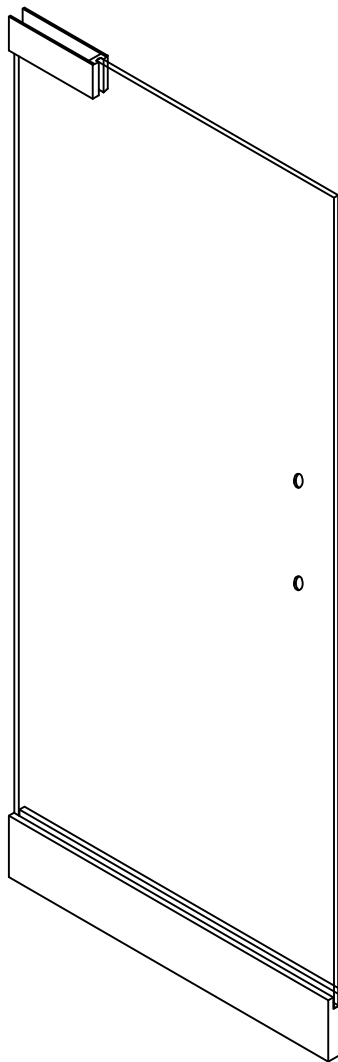

# BP-STYLE DOOR

**PRL** GLASS SYSTEMS INC.



## 9<sup>1</sup>/<sub>2</sub>" PL375 TOP PL375 BOTTOM

★ FINISHES AVAILABLE :  
# 8 POLISHED & # 4 SATIN  
STAINLESS  
US3 POLISHED & US4 SATIN  
BRASS ( NON LACQUER COATED)  
US10B  
ANODIZED PAINTED

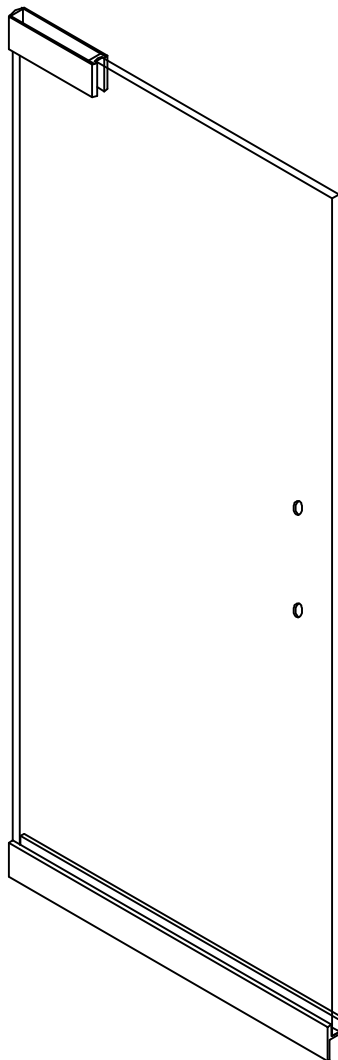

9<sup>1</sup>/<sub>2</sub>" PL-375 TOP PATCH RAIL  
(CLAD) BY P.R.L. GLASS

3/4" CLEAR TEMPERED GLASS  
BY P.R.L. GLASS

PL-375 BTM RAIL  
(CLAD)  
BY P.R.L. GLASS

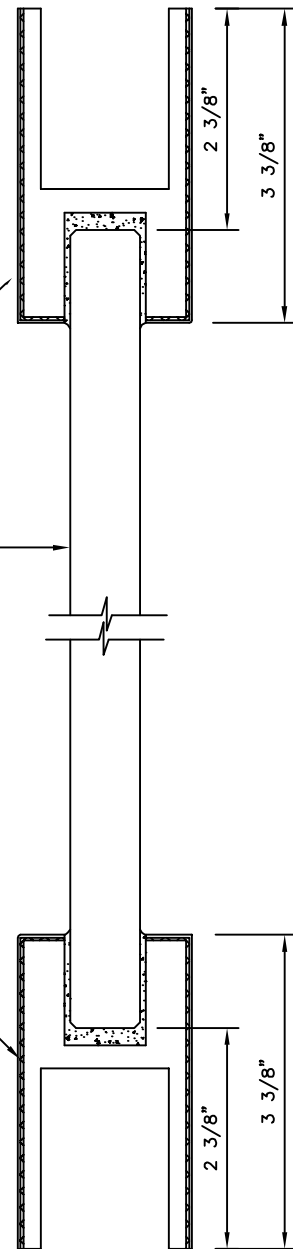

# BP-STYLE DOOR

## 9<sup>1</sup>/<sub>2</sub>" PL375 TOP PL1000 BOTTOM

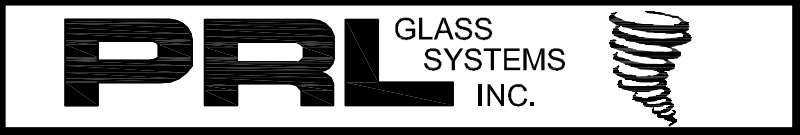

\* FINISHES AVAILABLE :  
# 8 POLISHED & # 4 SATIN  
STAINLESS  
US3 POLISHED & US4 SATIN  
BRASS ( NON LACQUER COATED)  
US10B  
ANODIZED PAINTED

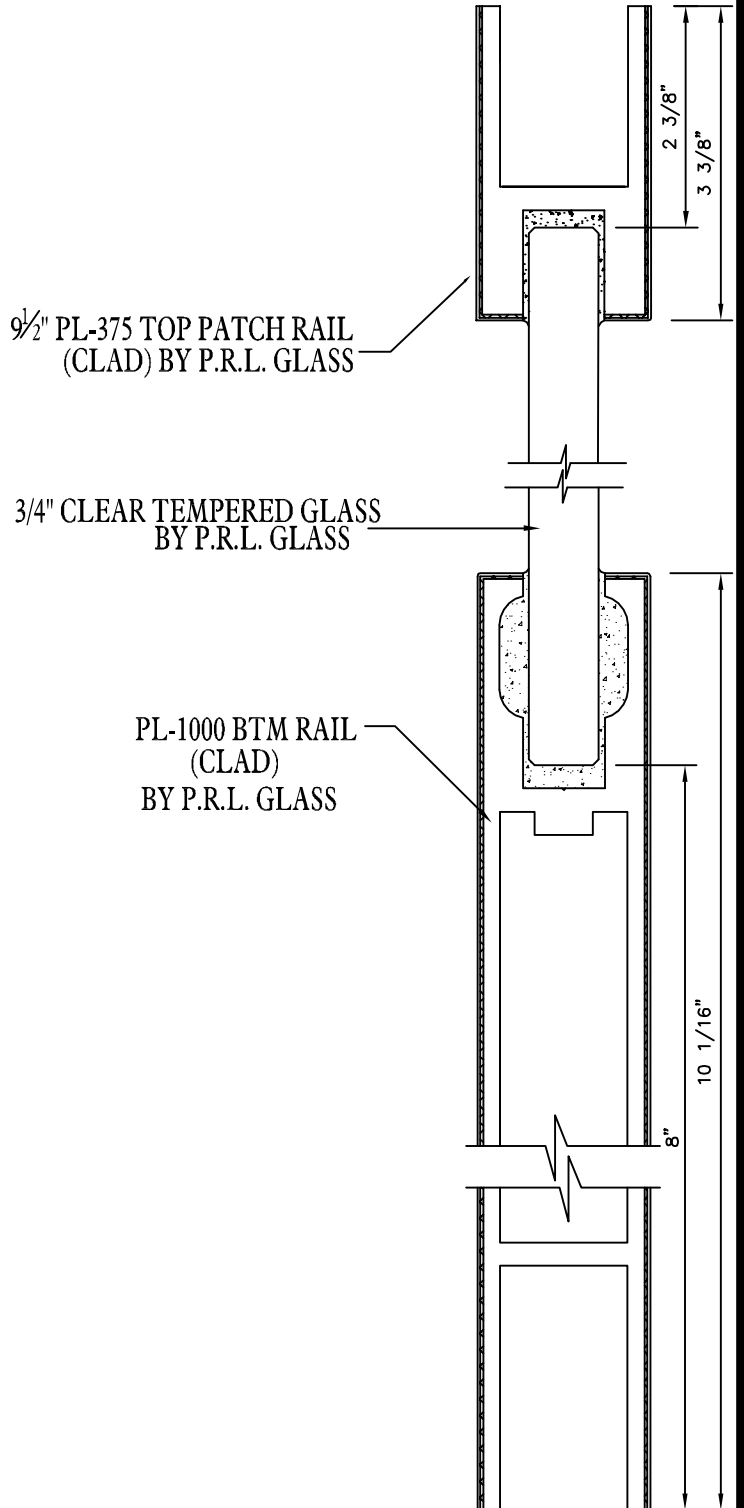
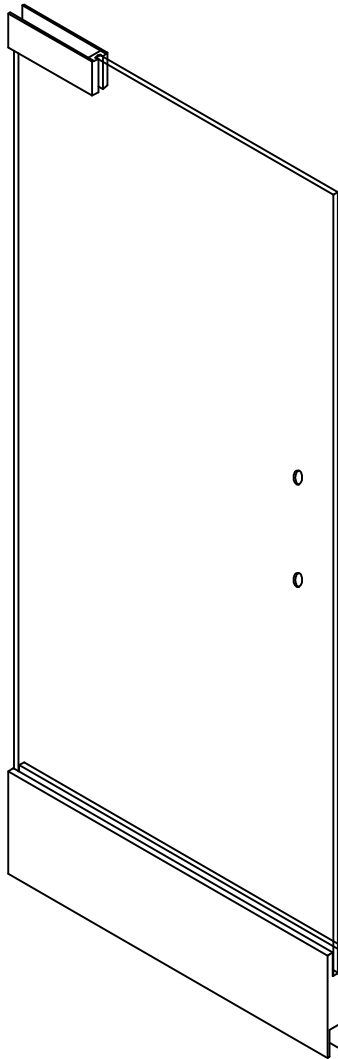



# BP-STYLE DOOR EURO TOP PATCH PL1000 BOTTOM

**PRL** GLASS SYSTEMS INC.



★ FINISHES AVAILABLE :  
# 8 POLISHED & # 4 SATIN  
STAINLESS  
US3 POLISHED & US4 SATIN  
BRASS ( NON LACQUER COATED)  
US10B  
ANODIZED PAINTED

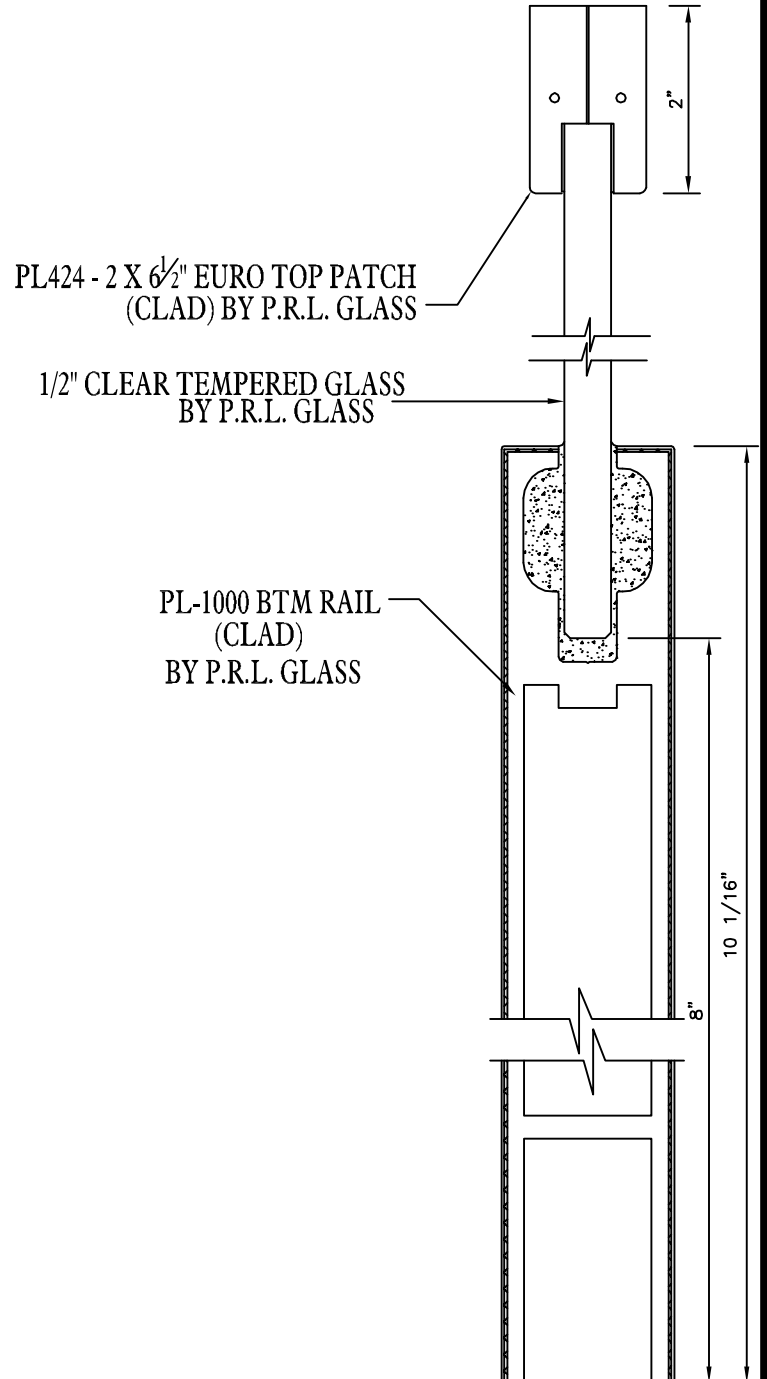
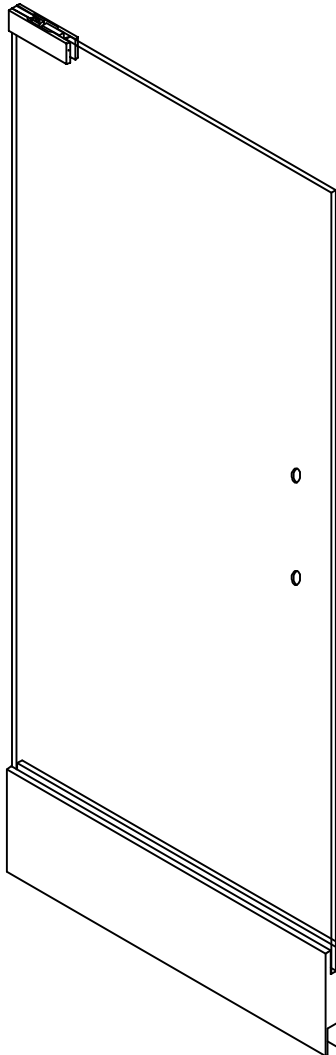

# BP-STYLE DOOR EURO TOP PATCH PL1000 BOTTOM

**PRL** GLASS SYSTEMS INC.



\* FINISHES AVAILABLE :  
# 8 POLISHED & # 4 SATIN  
STAINLESS  
US3 POLISHED & US4 SATIN  
BRASS ( NON LACQUER COATED)  
US10B  
ANODIZED PAINTED

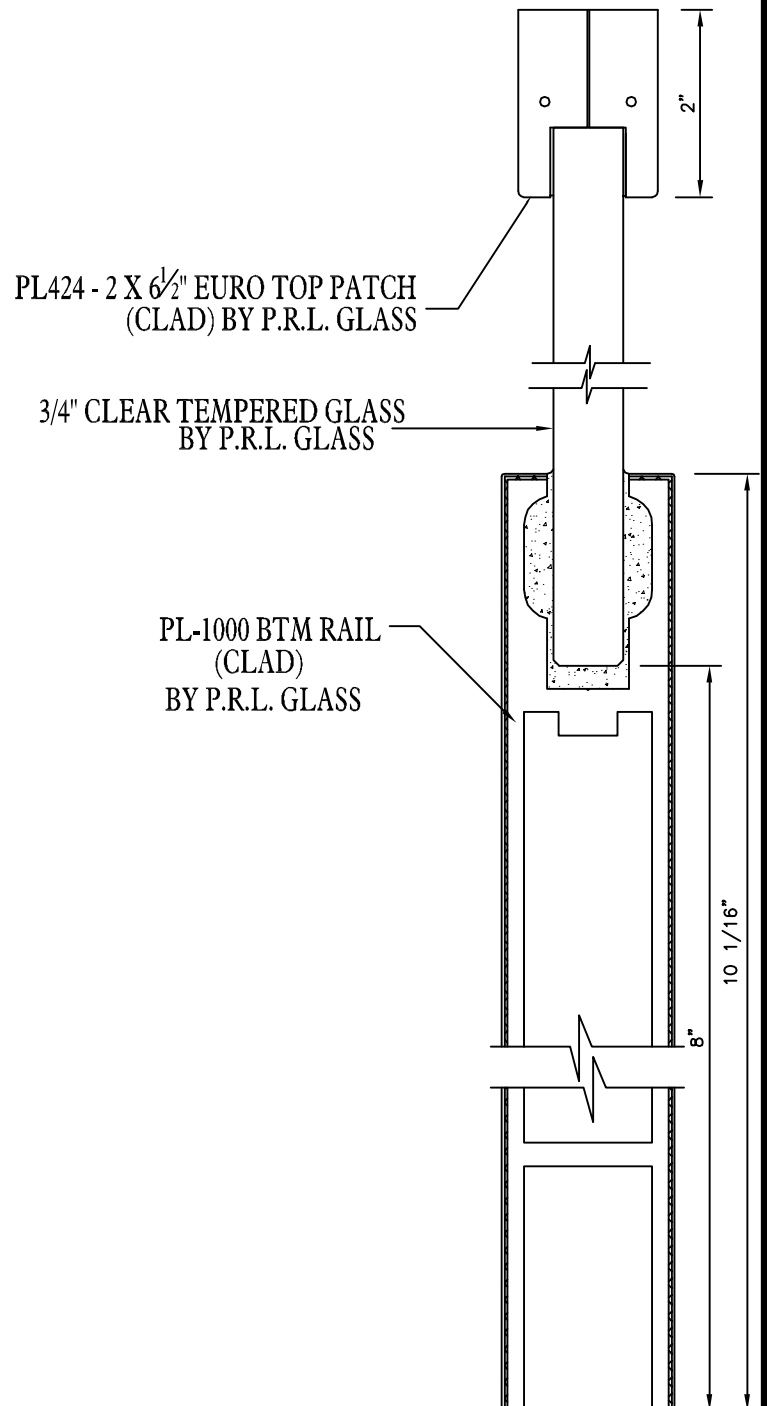
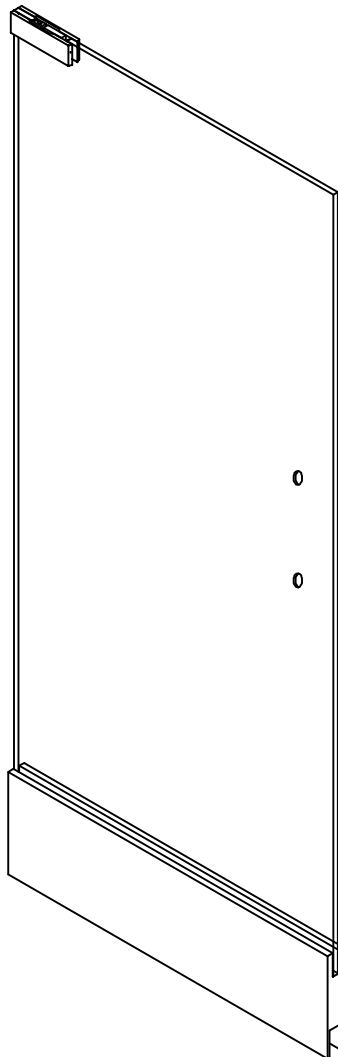

# BP-STYLE DOOR EURO TOP PATCH PL1075 BOTTOM

**PRL** GLASS  
SYSTEMS  
INC.



\* FINISHES AVAILABLE :  
# 8 POLISHED & # 4 SATIN  
STAINLESS  
US3 POLISHED & US4 SATIN  
BRASS ( NON LACQUER COATED )  
US10B  
ANODIZED PAINTED

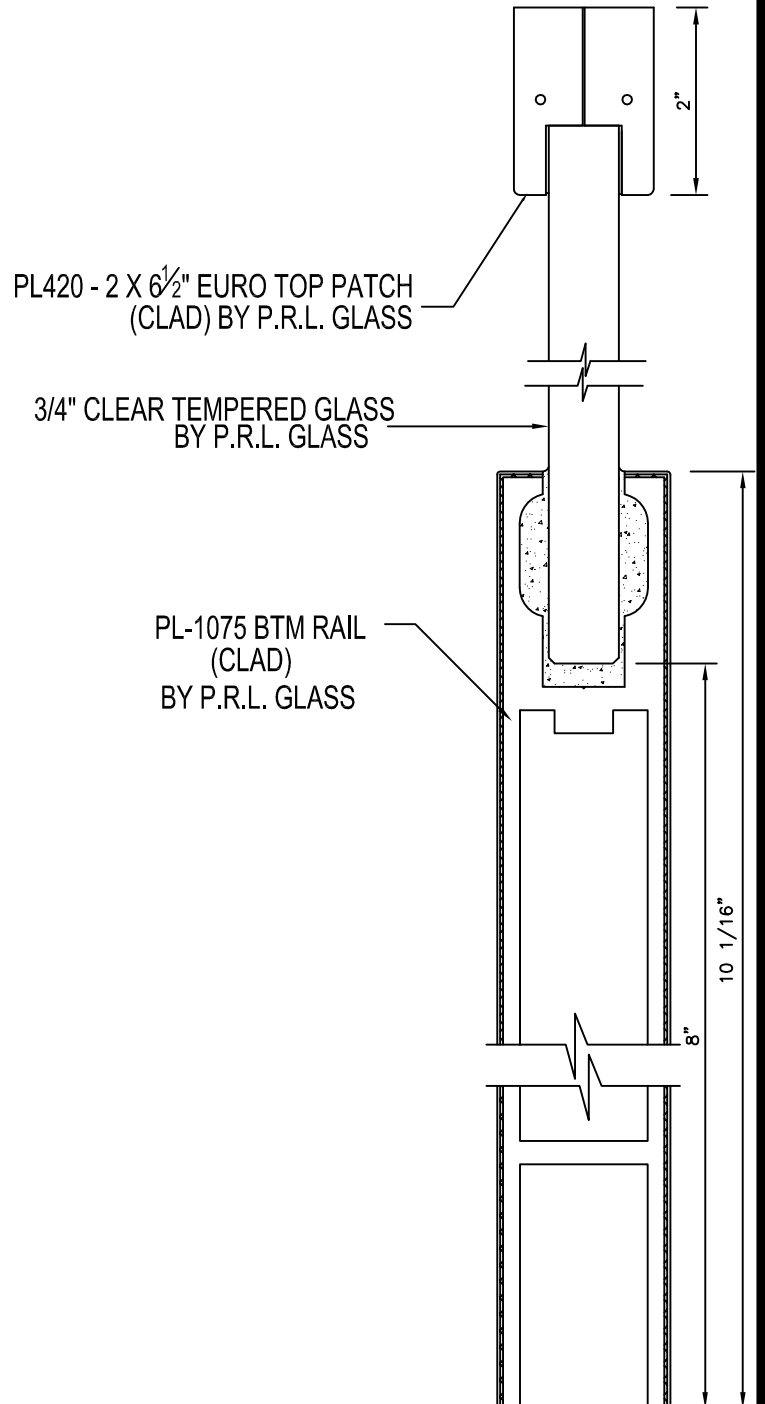
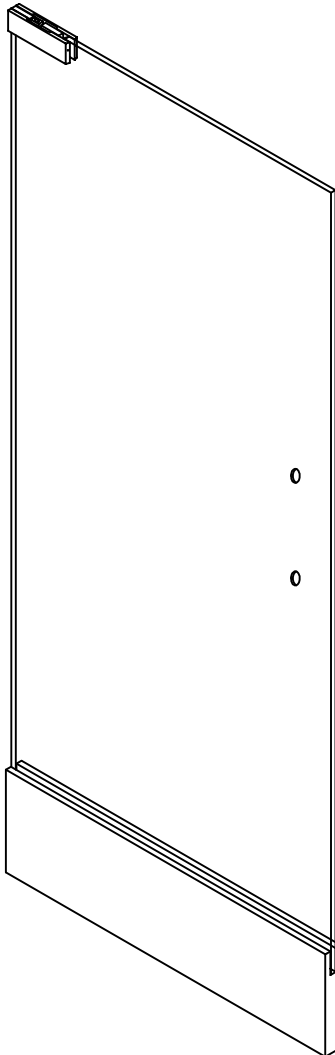

# BP-STYLE DOOR EURO TOP PATCH PL150 BOTTOM

**PRL** GLASS SYSTEMS  
INC.



★ FINISHES AVAILABLE :  
# 8 POLISHED & # 4 SATIN  
STAINLESS  
US3 POLISHED & US4 SATIN  
BRASS ( NON LACQUER COATED)  
US10B  
ANODIZED PAINTED

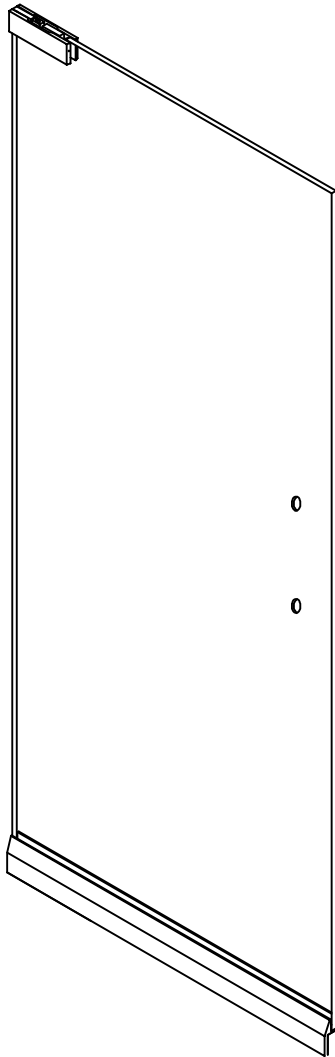

PL424 - 2 X  $6\frac{1}{2}$ " EURO TOP PATCH  
(CLAD) BY P.R.L. GLASS

$\frac{1}{2}$ " CLEAR TEMPERED GLASS  
BY P.R.L. GLASS

PL-150 BTM RAIL  
(CLAD)  
BY P.R.L. GLASS

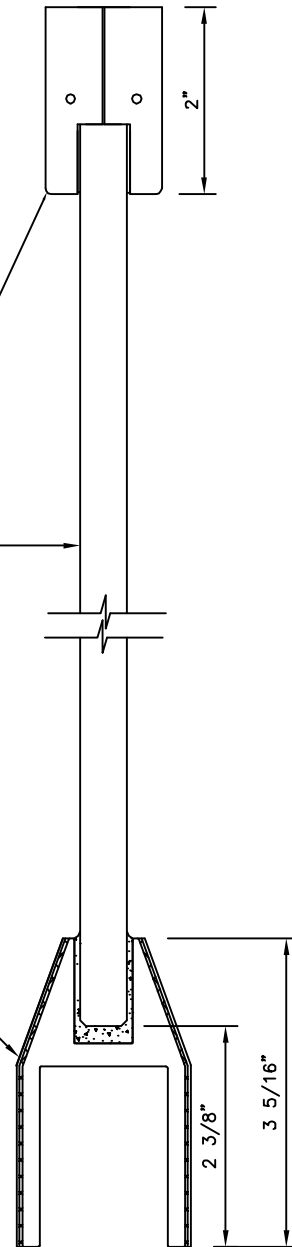

# BP-STYLE DOOR EURO TOP PATCH PL175 BOTTOM

**PRL** GLASS SYSTEMS  
INC.



★ FINISHES AVAILABLE :  
# 8 POLISHED & # 4 SATIN  
STAINLESS  
US3 POLISHED & US4 SATIN  
BRASS ( NON LACQUER COATED)  
US10B  
ANODIZED PAINTED

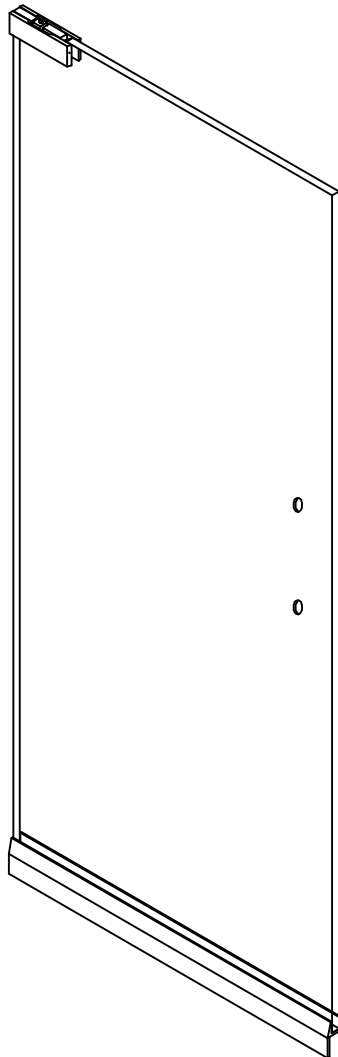

PL424 - 2 X 6 $\frac{1}{2}$ " EURO TOP PATCH  
(CLAD) BY P.R.L. GLASS

$\frac{3}{4}$ " CLEAR TEMPERED GLASS  
BY P.R.L. GLASS

PL-175 BTM RAIL  
(CLAD)  
BY P.R.L. GLASS

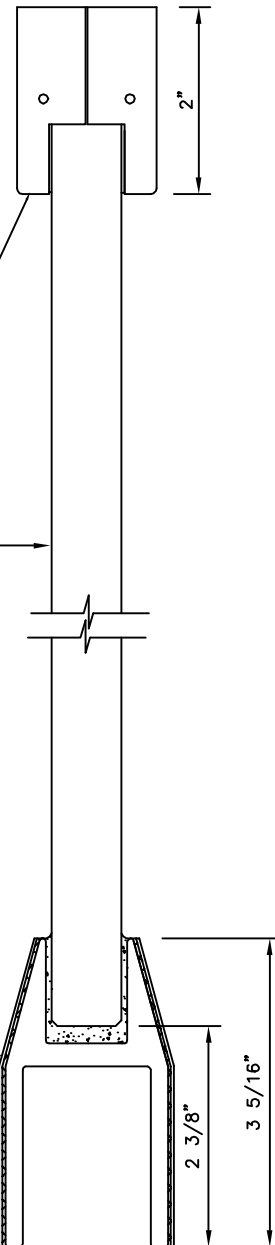

# BP-STYLE DOOR EURO TOP PATCH PL350 BOTTOM

**PRL** GLASS SYSTEMS  
INC.



★ FINISHES AVAILABLE :  
# 8 POLISHED & # 4 SATIN  
STAINLESS  
US3 POLISHED & US4 SATIN  
BRASS ( NON LACQUER COATED)  
US10B  
ANODIZED PAINTED

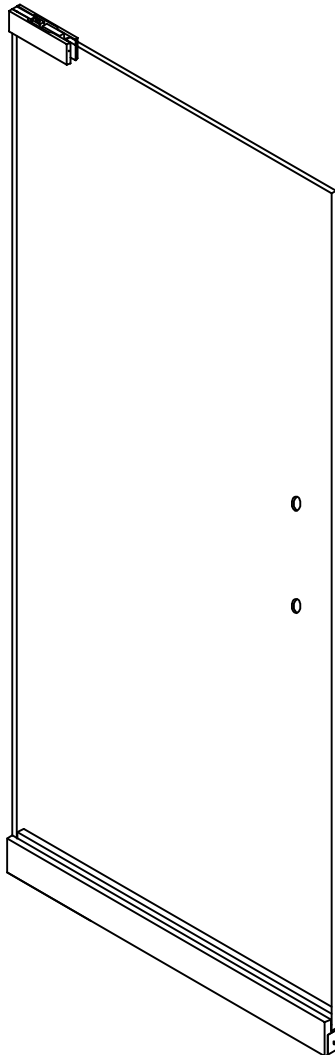

PL424 - 2 X 6 1/2" EURO TOP PATCH  
(CLAD) BY P.R.L. GLASS

1/2" CLEAR TEMPERED GLASS  
BY P.R.L. GLASS

PL-350 BTM RAIL  
(CLAD)  
BY P.R.L. GLASS

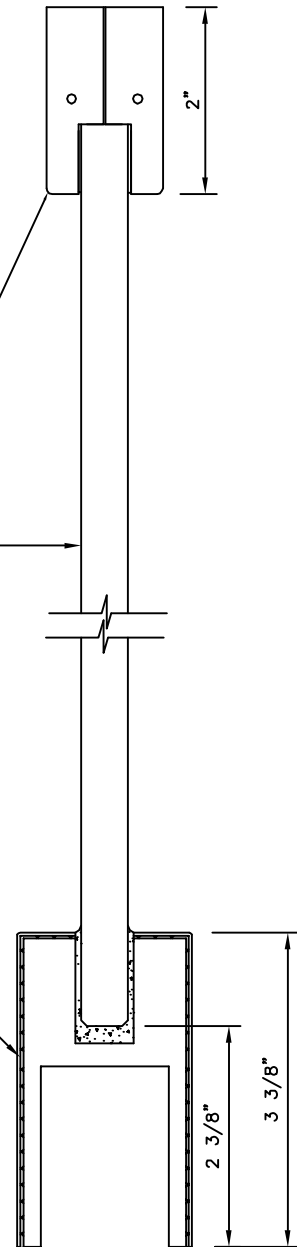

# BP-STYLE DOOR EURO TOP PATCH PL375 BOTTOM

**PRL** GLASS SYSTEMS  
INC.



★ FINISHES AVAILABLE :  
# 8 POLISHED & # 4 SATIN  
STAINLESS  
US3 POLISHED & US4 SATIN  
BRASS ( NON LACQUER COATED)  
US10B  
ANODIZED PAINTED

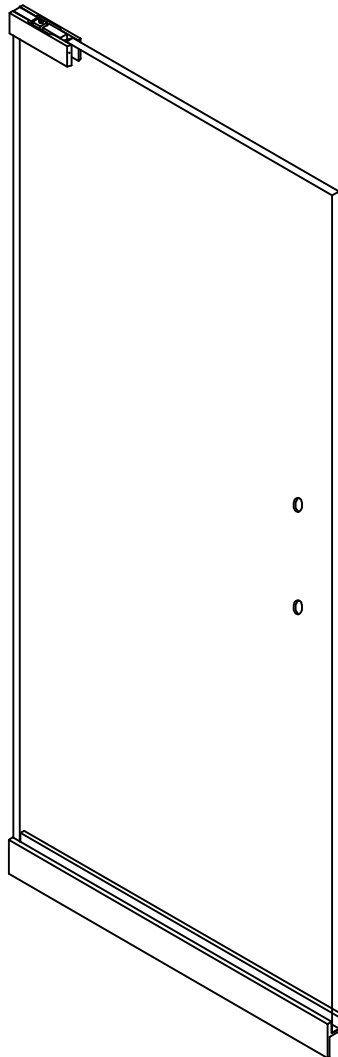

PL424 - 2 X 6 1/2" EURO TOP PATCH  
(CLAD) BY P.R.L. GLASS

3/4" CLEAR TEMPERED GLASS  
BY P.R.L. GLASS

PL-375 BTM RAIL  
(CLAD)  
BY P.R.L. GLASS

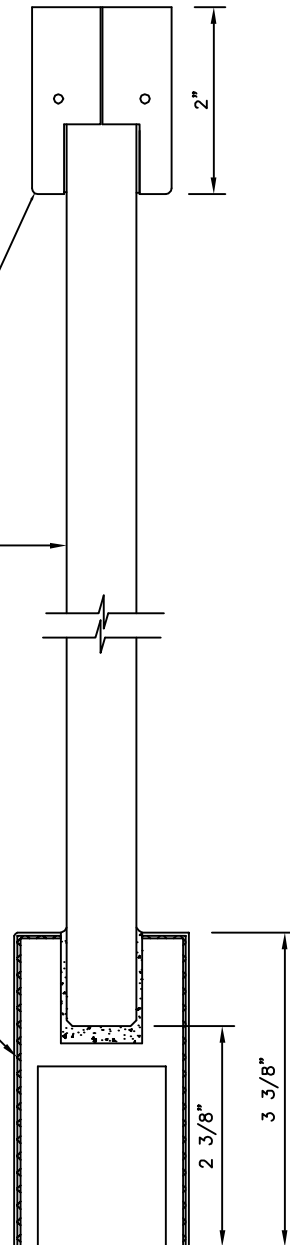

# BP-STYLE DOOR EURO TOP PATCH PL387 BOTTOM

**PRL** GLASS SYSTEMS INC.



★ FINISHES AVAILABLE :  
# 8 POLISHED & # 4 SATIN  
STAINLESS  
US3 POLISHED & US4 SATIN  
BRASS ( NON LACQUER COATED)  
US10B  
ANODIZED PAINTED

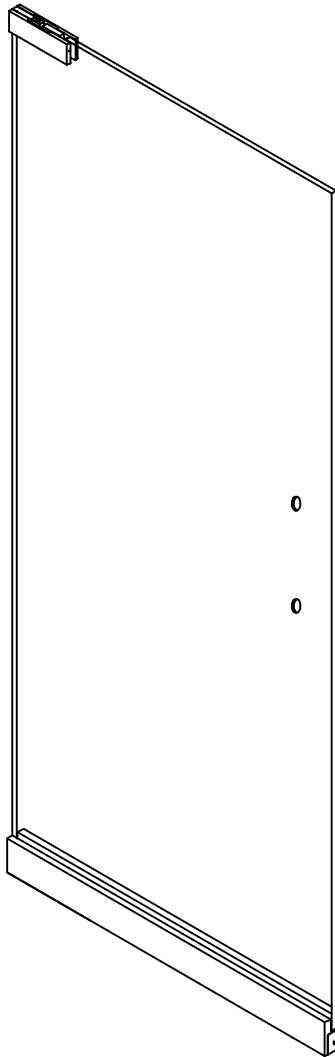

PL424 - 2 X  $6\frac{1}{2}$ " EURO TOP PATCH  
(CLAD) BY P.R.L. GLASS

$\frac{1}{2}$ " CLEAR TEMPERED GLASS  
BY P.R.L. GLASS

PL-387 BTM RAIL  
(CLAD)  
BY P.R.L. GLASS

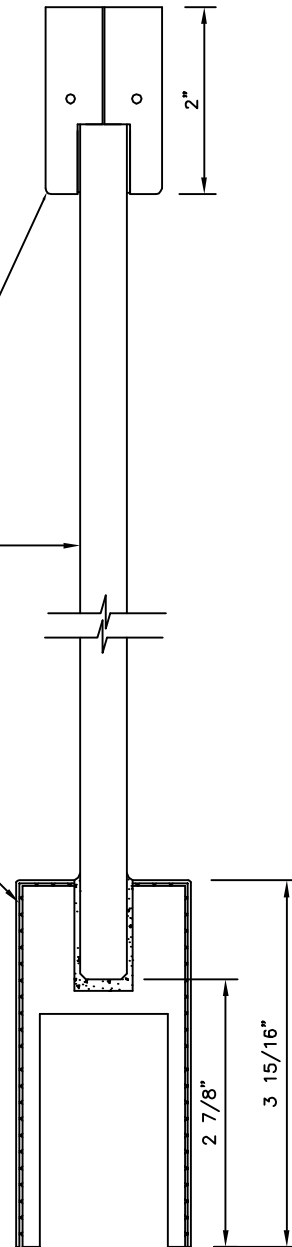



# BP-STYLE DOOR EURO TOP PATCH PL600 BOTTOM

**PRL** GLASS  
SYSTEMS  
INC.



★ FINISHES AVAILABLE :  
# 8 POLISHED & # 4 SATIN  
STAINLESS  
US3 POLISHED & US4 SATIN  
BRASS ( NON LACQUER COATED)  
US10B  
ANODIZED PAINTED

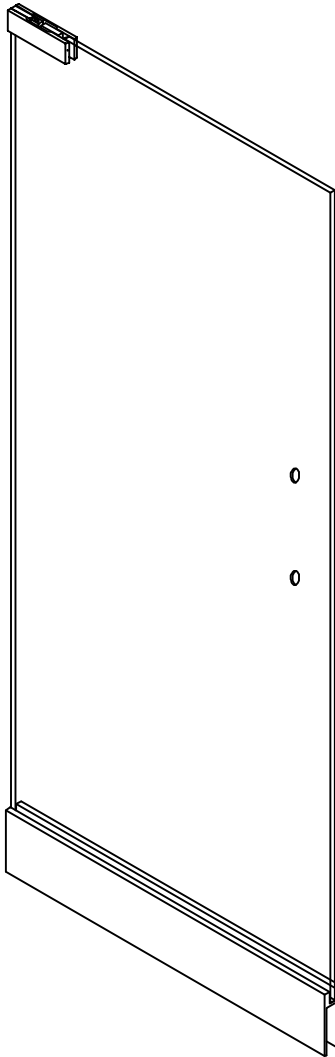

PL434 - 2 X 6 1/2" EURO TOP PATCH  
(CLAD) BY P.R.L. GLASS

1/2" CLEAR TEMPERED GLASS  
BY P.R.L. GLASS

PL-600 BTM RAIL  
(CLAD)  
BY P.R.L. GLASS

